

ALUMINUM RAIL

ERGONOMIC SOLUTIONS

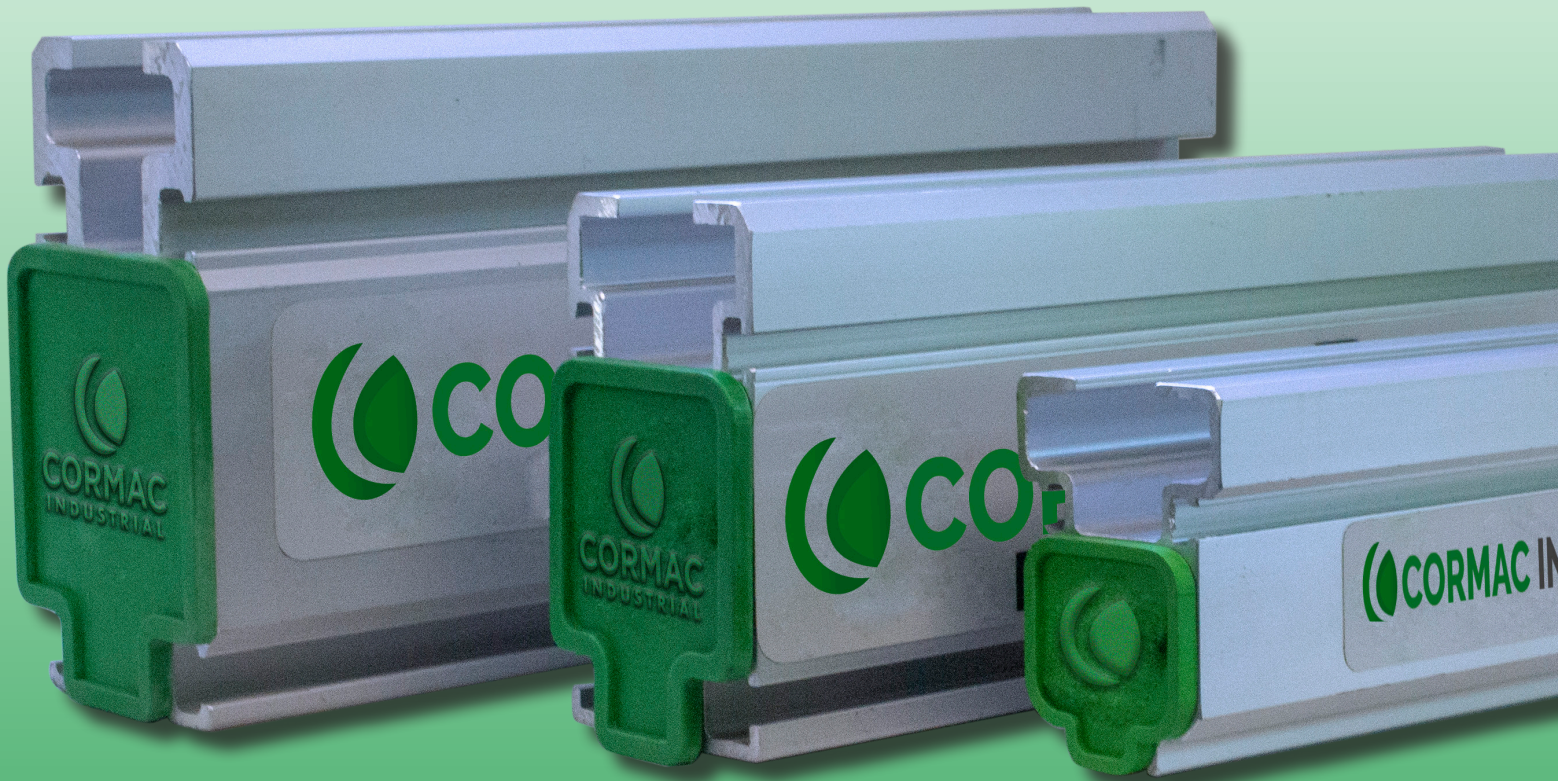

- *The ergonomic solution for movements of light loads up to 2000 lbs.
- *Rail systems, Monorails.
- *Ergonomic workstations.
- *Effortless and natural movements.



SCAN ME

35 YEARS OF EXPERIENCE SUPPORT OUR SOLUTIONS!

www.cormac-ind.com



ERGONOMIC RAIL SYSTEMS

Cormac Aluminum Rails

- * Robust, safe, lightweight and ergonomic, aluminum rail systems.
- * They are the answer to your ergonomic material handling needs.
- * Developed to exceed current industry standards.
- * Tested and certified to guarantee up to 5 times the specified capacity.
- * They can be installed easily and quickly, creating time and cost savings.
- * Natural aluminum surface finish, corrosion free!
- * Thanks to the inside geometry of the rail, it reduces the possibility of the accumulation of dirt on the rolling surface.
- * Ease of operations reducing operator effort with a smooth and silent glide.
- * This system has T-Slots on both sides of the rail which makes it easy to splice for extended runs and allows for additional accessories to be mounted directly to the rail.

The required force to move any load is 1% of total weight! *To break inertia*

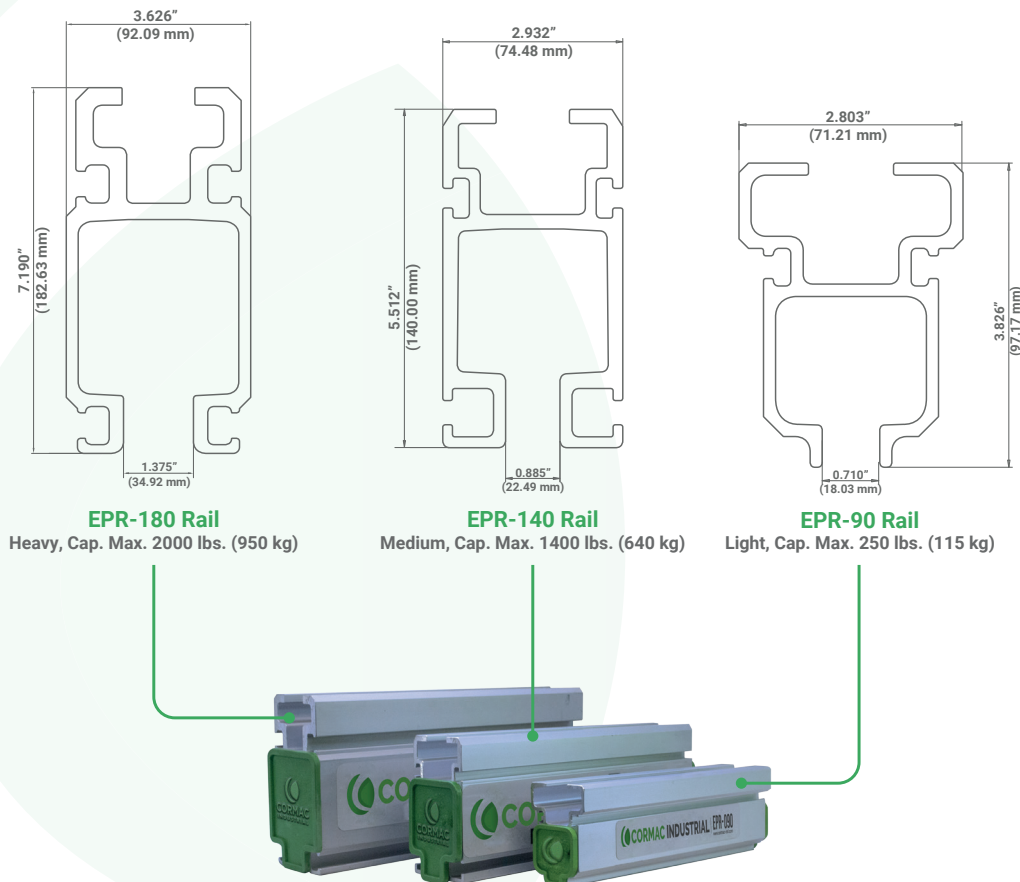

BRIDGE CRANE

Our bridge cranes are designed to move longitudinally on our rails on support trolleys called end trucks, this allows access to the full work area envelope

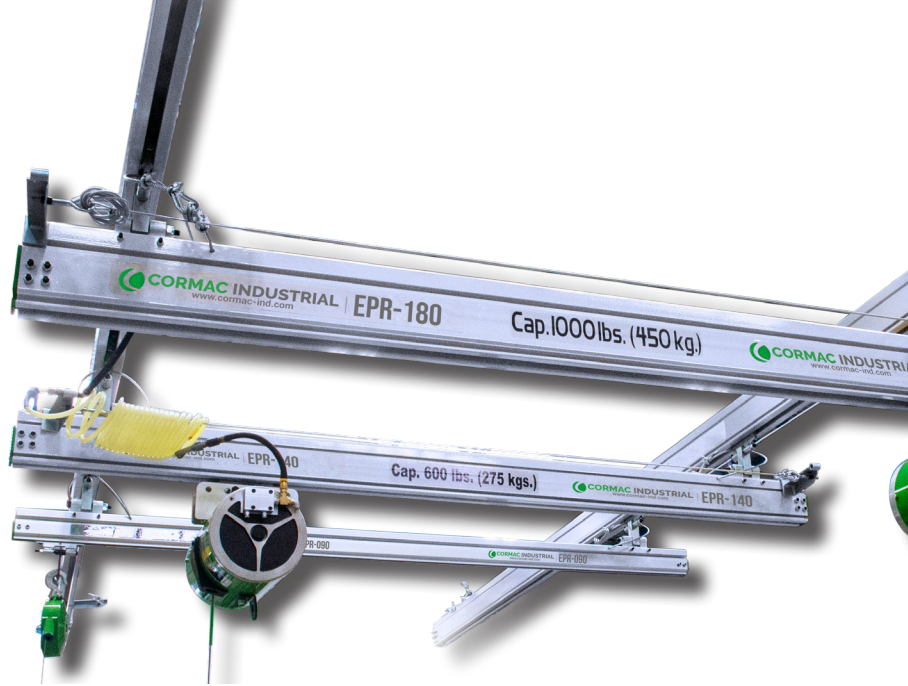

TROLLEYS

Other than the rail itself, the trolley selection is critical and determined by the customer's requirements. All Trolleys are equipped with double guide wheel, which use heavy duty bearings. Includes redundant rail safety lugs to prevent the trolley from being pulled through the rail.

Our wheels are made of the highest technology Dupont® polymer, which offers a long service life without undergoing deformations even under maximum load for long periods with a static load.



Hoist trolley simple

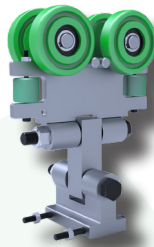

End truck

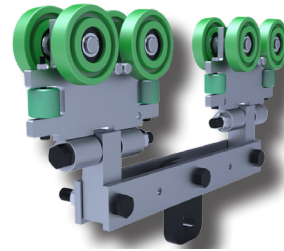

End truck doble

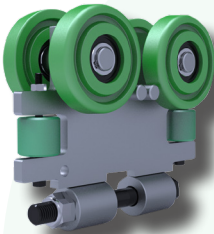

Trolley standar



Air Tractor



ACCESSORIES

RAIL END CAPS

We use redundant end caps to absorb the trolleys impact to guarantee the equipment safety. They are manufactured with rubber for smooth and safe operation.

RAIL SPLICE KIT

These kits are used to splice the rails making alignment and installation a breeze. With this solution extending rails is a simple task. Rails can be cut and joined at any part of the rail, just cut and splice to join it!. Important Note: A Hanger must be installed at the splice point.

HANGERS

Our hanger supports have been designed to mount our aluminum rail systems to "I" beam "C" beams and angle iron.

AIR SUPPLY FOR RAILS AND BRIDGE CRANES

The air supplies are available in 3/8 "and 1/2" ID hose and up to 50 ft. long. This kit is available for use with rails and bridge cranes.

Rails Kit: Filter regulator, shut-off valve, helical hose assembly, straight hose assembly, hose connections, steel cable line, eyebolt, air bracket assembly, and fixing clamp.

Bridge Crane Kit: Helical hose assembly, straight hose assembly, hose connections, steel cable line, eyebolt, air bracket assembly and fixing clamp.



Rail end caps

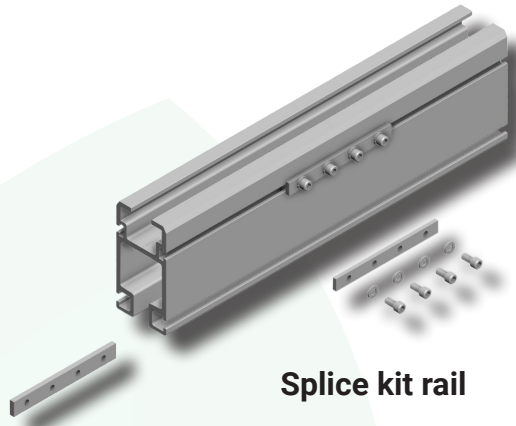

Splice kit rail



Hangers

Cormac Industrial® LLC (Texas) and its wholly owned Mexico subsidiary **CormacInd, S de RL de CV**, has designed, manufactured and installed nearly a thousand manipulator systems over the last 30 years with almost 90% of them delivered to Automotive and Transportation Industries in Mexico. Our design and manufacturing facilities are located in San Juan del Río, Queretaro. We manufacture our own enclosed aluminum rails systems under our Cormac trademarked brand. We extrude our aluminum rails in both Texas and Mexico and maintain inventories in both locations. Our technology is tried and proven.

Cormac Industrial® offers, very competitive pricing. We have distributors throughout Mexico, Columbia and in San Antonio Texas. We have developed a complete line of standard Material Handling products that are easily configured to your application: Aluminum Rail Systems (Leaders in Mexico) 3 families, R-90 Tool Rail, R-140 Medium Duty, R-180 Heavy Duty, Air Balancers & Zero Gravity Air Balancers, Custom Manipulators and standard manipulator components, Articulating Arms, Jib Arms, Pneumatic scissor Lift Tables & Lift Platforms.

CORMACIND, S. DE R.L. DE C.V.

Av. Benito Juárez 72, San Pedro Ahuacatlán C.P. 76810 San Juan del Río, Querétaro, México

www.cormac-ind.com

Tel: 55 8000 6540 / 55 8000 6536 / sales@cormac-ind.com